

Type FL - Flange Clamp

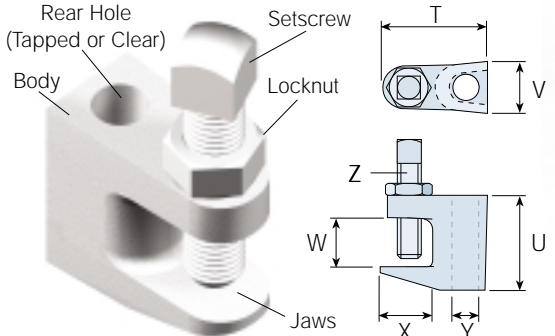

A1



The simplest, quickest and most cost-effective method of suspending building services from steel beams and suitable for use with parallel or tapered flange beams, the FL can be supplied with the back hole drilled to accept a plain rod or tapped to accept a threaded rod. The FL uses a grade 8.8 cup point setscrew to provide maximum bite into steelwork and maximum load performance.

| *Product Code | Drop Rod | Tensile Loads Safe Working Load 4:1 (kN) | Setscrew Torque (Nm) | Locknut Torque (Nm) | T | U | V | W | X | Y | Z |
|---------------|----------|--|----------------------|---------------------|----|----|----|----|----|----|----|
| FL16 | M6 | 1.1 | 8 | 11 | 36 | 35 | 19 | 17 | 20 | 7 | 8 |
| FL18 | M8 | 1.1 | 8 | 11 | 36 | 35 | 19 | 17 | 20 | 9 | 8 |
| FL210 | M10 | 2.4 | 8 | 22 | 45 | 40 | 22 | 19 | 22 | 11 | 10 |
| FL312 | M12 | 3.1 | 8 | 22 | 50 | 46 | 25 | 23 | 28 | 13 | 10 |
| FL412 | M12 | 3.1 | 8 | 22 | 53 | 51 | 26 | 28 | 27 | 13 | 10 |

* add T or P suffix to indicate preference of plain or tapped hole.

Installation

- Slide FL onto beam flange and tighten setscrew to recommended torque. To avoid over tightening, a rough guide to achieve the correct torque is to tighten the setscrew with thumb and forefinger and then apply a further quarter turn (90°) with a spanner. When used with taper flanges it is important to ensure that the setscrew of the FL bites into the tapered face of the flange, rather than the parallel underside.
- Tighten the locknut to the recommended torque.

NB. A Flange Clamp with a Hexagon Head is now available dependent on quantity, please contact Lindapter for details.

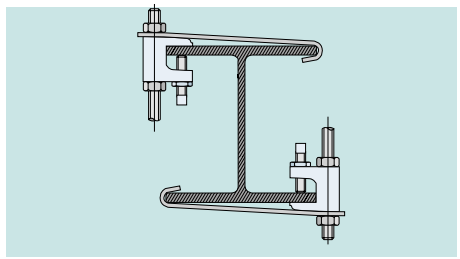
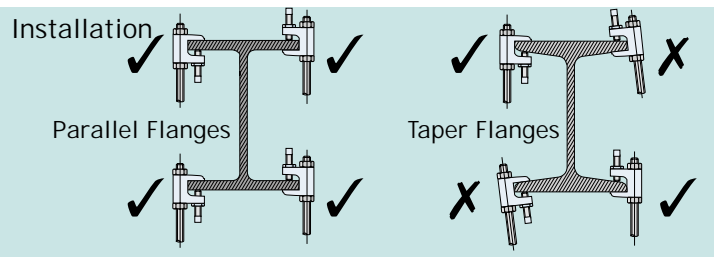

On applications supporting pipework above 65mm bore the additional safety strip should be used.
NOTE: This style of safety bracket can also be used on tapered flanges. Please contact Lindapter for details.